

# CELIO - CURVE

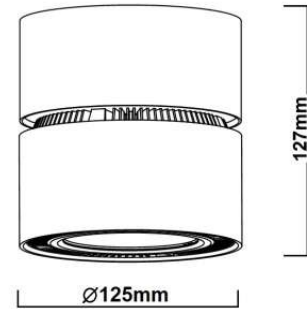

## DIMENSION



PRODUCT NAME	: CELIO - CURVE
PRODUCT TYPE	: ADJUSTABLE CEILING SPOT LIGHT
PRODUCT MATERIAL	: WHITE POWDER COATING ALUMINIUM
DIMENSION	: DIA 125mm. x H 127mm.
POWER CONSUMPTION	: 220V AC 50/60Hz
SURFACE FINISH	: WHITE POWDER COATING
ADJUSTABLE	: GIMBAL
INSTALLATION BY	: S.A. SPRING
LIGHT SOURCE	: BUILT-IN COB LED 12W / 18W 3000K
BEAM ANGLE	: 22°
WIRING	: TERMINAL BLOCK
IP RATING	: IP20

