

CLONA

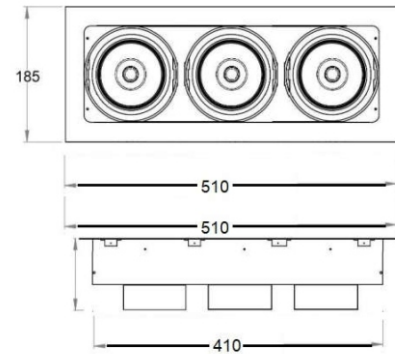

DIMENSION

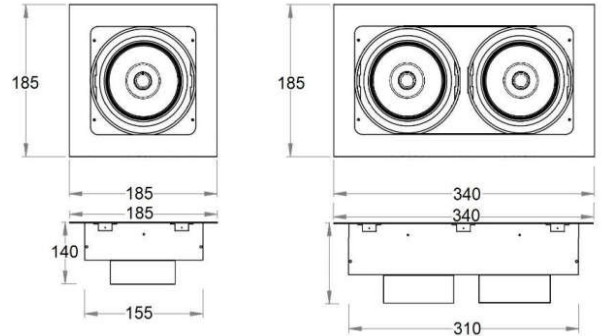

PRODUCT NAME	: CLONA
PRODUCT TYPE	: RECESSED DOWNLIGHT
PRODUCT MATERIAL	: ALUMINIUM HOOD METAL FRAME
DIMENSION	: CLONA-1 W 185mm. x L 185mm. x H 140mm. CLONA-2 W 185mm. x L 340mm. x H 140mm. CLONA-3 W 185mm. x L 510mm. x H 140mm.
POWER CONSUMPTION	: 220V AC 50/60Hz WITH 12V DC DRIVER 15/20/25/27/32W, 3000/4000/6000K, 24/36/60D
SURFACE FINISH	: WHITE / BLACK POWDER COATING
ADJUSTABLE	: GIMBAL
INSTALLATION BY	: S.A. SPRING (RECESSED CEILING)
DIMMABLE	: 1-10V, DALI, PHASE 220V
DIFFUSER	: PMMA 92%
IP RATING	: IP20

