

CLONOS - BOX

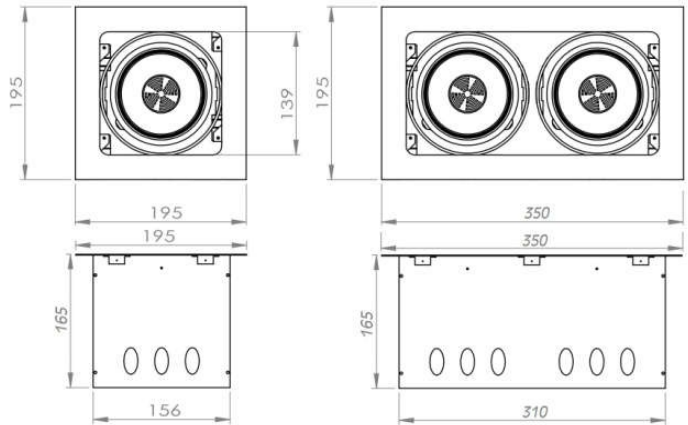

DIMENSION



PRODUCT NAME	:	CLONOS - BOX
PRODUCT TYPE	:	RECESSED DOWNLIGHT
PRODUCT MATERIAL	:	METAL FRAME / ALUMINIUM HOOD
DIMENSION	:	W 195mm. x L 195mm. x H 165mm.
	:	W 195mm. x L 350mm. x H 165mm.
POWER CONSUMPTION	:	220V AC 50/60Hz WITH TRANSFORMER 12V DC
SURFACE FINISH	:	WHITE / BLACK POWDER COATING
ADJUSTABLE	:	NO
INSTALLATION BY	:	S.A. SPRING (RECESSED CEILING)
WIRING	:	TERMINAL BLOCK COB
IP RATING	:	IP20

